

# Sharp-Rejection Technique in High Frequency Active-RC LPF for UWB Applications

Anh Tuan Phan, Ronan Farrell, and Sang- Gug Lee

**Abstract**—This paper describes a sharp-rejection technique in designing active-RC LPF for MB-OFDM UWB applications. Sharp rejection is attributed to the combination of different AC characteristic of three Biquads in series. A simple operational amplifier (Op-amp) is adopted to ensure high frequency and high linear performance for the designed filter. The cutoff frequency is 264MHz, with 13dB rejection at 290MHz and about 50dB at twice bandwidth. The LPF is designed in 0.13 $\mu$ m IBM CMOS process with pass-band ripple of less than 1dB, IIP3 is 23dBm while consuming 8.4mA from 1.5V supply.

**Index Terms**—Continuous-time filters, High frequency filters, Op-amp, UWB, LPF, Sharp rejection, CMOS.

## I. INTRODUCTION

LOW Pass Filter (LPF) is a key building block in the transceivers, mostly designed for channel selection and anti-alias [1]. Especially in the MB-OFDM UWB, the interference from adjacent channel is severe. In MB-OFDM UWB [2], the whole UWB spectrum is divided into several sub-channels. Each of these channels can easily cause the interference on its both side adjacent one or in an opposite way, therefore the accumulated interferences from other channels can overlap on one given channel. Because of that severe inherent characteristics of MB-OFDM, high performance LPF is needed. The LPF is required to have high rejection ratio, so that it can suppress the interference from adjacent channels. Moreover, it should have high linearity and wide bandwidth to meet the requirement of UWB.

## II. LPF DESIGN

Rejection ratio or attenuation ratio is defined as the different level of signal in the pass-band compared to that at a given

Manuscript received September 16<sup>th</sup>, 2008.

The authors would like to thank Science Foundation Ireland for their generous funding of the research through the Centre for Telecommunication Value-Chain Research (CTVR). This work was supported in part by the Korea Science and Engineering Foundation (KOSEF) through the Ministry of Science and Technology (MOST).

Tuan Anh Phan and Ronan Farrell are with the Institute of Microelectronics and Wireless System, National University of Ireland, Maynooth (NUIM), Maynooth, Kildare, Ireland. (corresponding author: +353-1-708 6305; fax: +353-1-708-6207; e-mail: aphan@eeng.nuim.ie).

Sang-Gug Lee is with the Information and Communications University (ICU), Daejeon, Korea.

frequency. In this design, the requirements for rejection at 290MHz and at twice the channel bandwidth, 528MHz, are -12dB and -30dB, respectively. The sharp slope rejection from 264MHz to 290MHz is the most challenging. High linearity feature is also demanded, hence, out of band interferences do not create inter-modulations which fall in the pass-band. The order of the filter is determined based on the type of filter, cutoff frequency and signal attenuation ratio requirement. Classical configurations are Bessel, Chebyshev, Elliptical and Butterworth filters. Among them, Butterworth give the high rejection ratio with the same order while requires a reasonable Q factor. To achieve high rejection ratio as required, the number of order for Butterworth LPF ( $n_{Bu}$ ) calculated from (1) should be larger than 20 based on the theory analysis in [3], resulting to a very complex, large chip size and high power circuit.

$$n_{Bu} = \frac{\log \left[ \frac{(10^{0.1\alpha_{\min}} - 1)}{(10^{0.1\alpha_{\max}} - 1)} \right]}{2 \log(\omega_s / \omega_p)} \quad (1)$$

where  $\omega_s$  and  $\omega_p$  is the stop-band and pass-band frequency,  $\alpha_{\max}$  is the ripple at the pass-band and  $\alpha_{\min}$  is the attenuation at the stop-band. In order to satisfy the sharp rejection ratio, a new technique is proposed which employs the steep slope around the peaking point. In this design, 6<sup>th</sup> order LPF topology is chosen as a compromise of those constraints, shown in Fig.1.

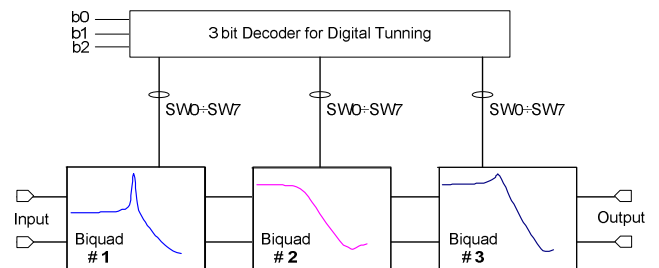

Fig. 1. 6<sup>th</sup> order LPF structure

## III. PROPOSED SHARP REJECTION TECHNIQUE

The main idea is to make use of the steep slope at the peaking point which has high Q factor. In order to have high rejection ratio, the three different AC characteristics of the

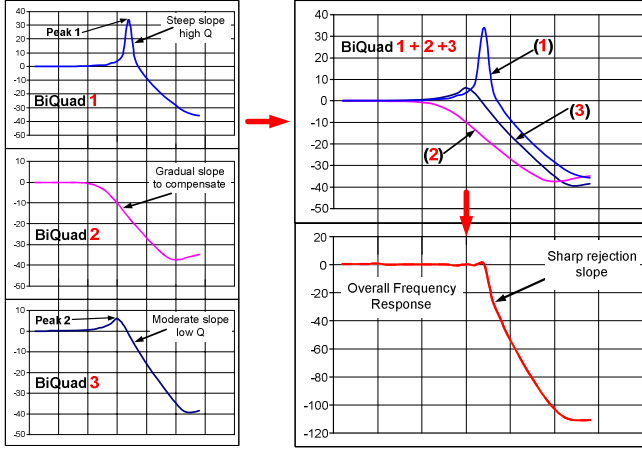

Fig. 2. Combination of three different biquad's AC characteristic

three biquads are combined as in Fig. 1. Each BiQuad has the peaking at different frequencies with different Q factors. These peaking frequencies in each biquad are determined and optimized during the simulation. When cascading them, the frequency responses are combined, at the cut-off frequency, sharpest slope is obtained while at other frequencies in the pass-band, flat AC response is achieved by compensation of different frequency responses.

From Fig. 2, BiQuad 1 has highest peaking at the cutoff frequency (at 260MHz), leading to a sharp slope. BiQuad 2 has high attenuation at the cutoff frequency to compensate with the frequency response of BiQuad 1. Hence, BiQuad 3 should have moderate peaking at lower frequencies (at 150MHz) to compensate with the attenuation of BiQuad 1 at these low frequencies. As a result, when the three frequency responses of biquads are combined, flat frequency response in the pass-band is achieved with very sharp attenuation at the corner frequency with. The order arrangement of three Biquads also helps reduce the noise figure (NF). Because the NF depends mostly on the first stage, thus, the first stage should have higher gain or high peaking.

#### IV. LPF DESIGN

Operational amplifier (Op-amp) is the core circuit in designing the RC LPF. It determines the frequency characteristics, linearity and voltage swing of the whole LPF.

The Op-amp has two stages, transconductance stage ( $g_m$ ) and the output buffer, shown in Fig. 3. The buffer stage has the unit gain and its main function is for the output impedance matching. A cross connection at the PMOS load transistors  $M_{5,6}$  is adopted. This cross connection creates the negative transconductance ( $-g_{mc}$ ) which compensate positive  $g_{mp}$  of the diode connected PMOS. Thus the load ( $R_L$ ) in (2) is increased leading to the improvement of the gain as specified in (3).

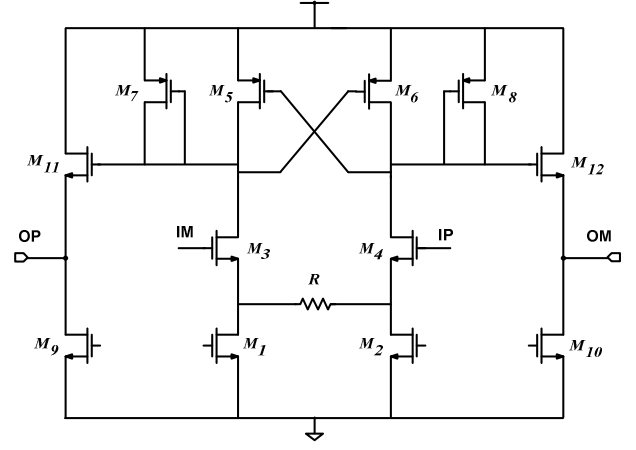

Fig. 3. Op-Amp topology

$$R_L = \left(-\frac{1}{g_{mc}}\right) // \frac{1}{g_{mp}} = \frac{-\frac{1}{g_{mc}} \times \frac{1}{g_{mp}}}{\frac{1}{g_{mp}} - \frac{1}{g_{mc}}} = \frac{1}{g_{mc}} \times \frac{1}{g_{mp}} \quad (2)$$

$$G_V = \frac{g_m \times R_L}{1 + g_m \times R_{\text{degeneration}}} \quad (3)$$

The Op-amp has two poles, the dominant one is at the output node and the other one is at the drain of PMOS load transistors. Those transistor sizes are selected with small channel length to put the pole far away from the dominant one. Thus, the Op-amp has very high frequency characteristic. Degeneration resistor R is used to increase the linearity of the Op-amp as well as of overall LPF.

#### V. EXPERIMENT RESULTS

The UWB LPF is designed using IBM 0.13- $\mu\text{m}$  CMOS technology in Cadence with the voltage supply of 1.5 V.

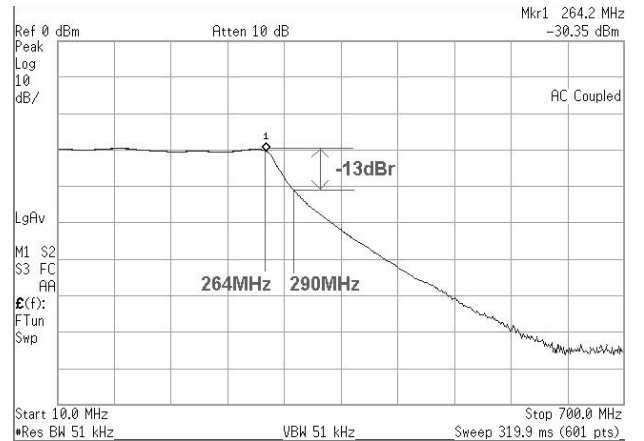

Fig. 4. AC characteristic of the designed UWB LPF.

The frequency characteristic of the designed LPF is shown in Fig. 4. The cutoff frequency at 1dB is 264MHz. The ripple is less than 1dB resulting to almost constant group delay along the pass-band. At 290MHz the attenuation is 13dB, at twice the channel bandwidth, 528MHz, the attenuation is about

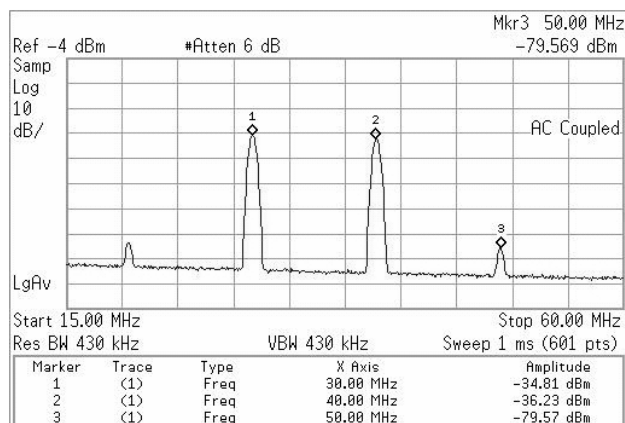

Fig. 5. Two-tone in-band IM3 test at 30 MHz and 40 MHz.

50dB. This filter shows very sharp slope in the range from 264MHz to 290MHz, compared to other filters with the same order designed in conventional way by cascading a number of small order same-Q filter stages. Digital tuning is applied to deal with process variation and the tuning range is from 190MHz to 310MHz, about 40%. In Fig. 5, two-tones test at 30MHz and 40MHz shows high linearity performance with 23dBm of IIP3 and P1dB is 3dBm. The total current consumption of the LPF is 8.4mA or 12.6mW. This LPF has the smallest power consumption compared with state of the art published works for wideband applications.

## VI. CONCLUSION

A wide-band, high linear sharp-rejection LPF for MB-OFDM UWB was designed in 0.13 $\mu$ m IBM CMOS process. Experiment results have proved the effectiveness of the proposed technique. The designed LPF has very sharp rejection ratio, -13dB rejection at 290MHz while cutoff frequency is 264MHz. It consumes 8.4mA from 1.5V, and the chip size of 400 $\mu$ m x 640 $\mu$ m. The designed filter, among the first few designs of wide-band active-RC LPF, shows very good performance making it really suitable for multi-band and wide-band applications like UWB.

## REFERENCES

- [1] Z. Hui, L. Shuzuo, L. Dongtian, S. Cheng, C. Tatfu, and H. C. Luong, "A 3.1-8.0 GHz MB-OFDM UWB Transceiver in 0.18 $\mu$ m CMOS," *IEEE Custom Integrated Circuits Conf. (CICC)*, Sept. 2007, pp. 651-654.
- [2] "Multi-band OFDM Physical Layer Proposal for IEEE 802.15.3a Task Group," IEEE P802.15 Working Group for Wireless Personal Area Networks, March, 2004.

- [3] Rolf Schaumann and Mac E. Van Valkenburg, "Design of Analog filter", New York, Oxford Press, 2001.

**Tuan Anh Phan** was born in Hanoi, Vietnam in 1979. He received the B.S. degree (5 year degree) in Electronics and Telecommunications from Hanoi University of Technology (HUT), Vietnam in 2002, and the M.Sc. and Ph.D degrees in Electrical Engineering from Information and Communications University (ICU), Daejeon, Korea in August 2004 and February 2008 respectively. He was with Electronic and Telecommunication Research Institute (ETRI), Korea from April 2007 to October 2007 as an intern for the development of the Pulse-Based UWB Transceiver for WPAN.

He is now working as a Post Doctoral Researcher at the Institute of Microelectronics and Wireless Systems (IMWS), National University of Ireland, Maynooth, Ireland.

His current research interests are CMOS RFIC design, UWB Radio transceiver design, Reconfigurable Radio, and low power low cost circuit solutions.

**Ronan Farrell** is from Clondalkin, Dublin, Ireland. He graduated from University College Dublin in 1993 with a B.E. and proceeded to work with ICI/Zeneca Chemicals for the next two years in Louisiana, USA, and on various sites in Yorkshire, England. In 1995 he returned to University College Dublin to start on a Masters on Sigma-Delta Modulators, sponsored by Analog Devices. This developed into a Ph.D., which he received in 1998.

After receiving his Ph.D. he joined Silicon Systems Limited (SSL) which was to become Parthus Technologies after going public. He worked within the mixed signal group designing custom silicon chips, ranging from low frequency, low power, applications to 2.4 GHz phase-lock loops. His areas of expertise are in system modelling and development, digital and analog design at low and medium frequencies, and in particular data converters utilising oversampling techniques.

He left Parthus Technologies in 2001 and took an academic position with the National University of Ireland, Maynooth. Currently he is a lecturer in the Department of Electronic Engineering at NUI, Maynooth. His courses currently include Analog Electronics (GE204) and Solid State Electronics (GE201).

**Sang-Gug Lee** was born in Gyungnam, Korea in 1958. He received the B.S. degree in electronic engineering from the Gyungbook National University, Korea, in 1981, and the M.S. and Ph.D. degrees in electrical engineering from the University of Florida, Gainesville, in 1989 and 1992, respectively. In 1992, he joined Harris Semiconductor, Melbourne, Florida, USA, where he was engaged in silicon-based RF IC designs. From 1995 to 1998, he was with Handong University, Pohang, Korea, as an assistant professor in the school of computer and electrical engineering. Since 1998, he is with Information and Communications University, Daejeon, Korea, where he is now a professor. His research interests include the silicon technology-based (BJT, BiCMOS, CMOS, and SiGe BICMOS) RF IC designs such as LNA, mixer, oscillator, power amp, etc. He is also active in the high-speed IC designs for the optical communication such as the TIA, driver amp, limiting amp, CDR, mux/demux, etc..